

CX800 Crawler Excavators

Table of Contents

DIVISION/SECTION	SECTION N°	REFERENCE N°
1 GENERAL INFORMATION		
Safety, general information and standard torque data	1001	9-36810GB
General specifications and special torque setting.....	1002	9-36520GB
2 ENGINE		
Removal and installation of the engine	2000	9-36800GB
Radiator and oil-cooler	2001	9-42540GB
Engine specifications	*	
Disassembly and assembly of the engine.....	*	
3 FUEL SYSTEM		
Fuel tank	3001	9-36820GB
Fuel engine system.....	*	
4 ELECTRICAL SYSTEM		
Electrical system, electrical and electronic troubleshooting	4001	9-36850GB
Inspection and maintenance of batteries and connecting a booster battery ...	4002	9-36830GB
Main and engine electronic control boxes.....	4003	9-36840GB
5 UNDERCARRIAGE		
Removal and installation of tracks	5001	9-36860GB
Rollers.....	5003	9-36880GB
Sprocket.....	5004	9-36890GB
Idler wheel and tension shock absorber	5005	9-36900GB
6 DRIVE TRAIN		
Drive motor and final drive transmission removal and installation	6001	9-36980GB
Drive motor and final drive transmission disassembly and assembly	6002	9-40350GB
Swing reduction gear, removal and installation.....	6003	9-36990GB
Swing reduction gear, disassembly and assembly	6004	9-42630GB
7 UNDERCARRIAGE HYDRAULICS		
8 UPPERSTRUCTURE HYDRAULICS		
Depressurising and decontaminating the hydraulic system, use of the vacuum pump and bleeding the components	8000	9-40270GB
Specifications, troubleshooting, checks and hydraulic pressure settings	8001	9-35970GB
Hydraulic reservoir removal and installation	8002	9-40280GB
Main and pilot pumps, removal and installation	8003	9-40770GB
Main hydraulic control valve, removal and installation.....	8004	9-40910GB
Attachment cylinders, removal and installation.....	8005	9-27791GB
Hydraulic swivel, removal and installation	8006	9-40920GB
Pilot blocs, removal and installation.....	8007	9-40930GB
Swing motor, removal and installation	8008	9-40260GB
Main hydraulic pump, disassembly and assembly.....	8010	9-42560GB
Main hydraulic control valve, disassembly and assembly.....	8011	9-42760GB
Attachment cylinders, disassembly and assembly.....	8012	9-40940GB
Hand control levers, disassembly and assembly	8013	9-40980GB
Foot control levers, disassembly and assembly	8014	9-40990GB
Eight-solenoid valves, disassembly and assembly	8015	9-42520GB
Caution valve, disassembly and assembly	8016	7-27941GB
Safety valve	8017	9-42770GB
Hydraulic swivel, disassembly and assembly	8018	9-42510GB
Swing motor, disassembly and assembly	8019	9-42530GB
Hydraulic functions.....	8020	9-42640GB

DIVISION/SECTION	SECTION N°	REFERENCE N°
9 UPPERSTRUCTURE		
Upperstructure, turntable and counterweight.....	9002	9-42550GB
Boom, dipper and bucket.....	9003	9-42620GB
Seat and seat belt.....	9004	9-40960GB
Cab and cab equipment.....	9005	9-40970GB
Air conditioning troubleshooting.....	9006	██████████
Air conditioning unit disassembly and assembly.....	9007	██████████
Air conditioning servicing.....	9008	██████████
Air conditioning components.....	9009	██████████
Removal and installation attachment, counterweight and side fram.....	9010	9-36340GB
Large format hydraulic and electrical schematics.....	Pocket	7-29440GB

* Consult the Engine Service Manual

██████████ Sections to be distributed at a later date

NOTE: CASE Company reserves the right to make changes in the specification and design of the machine without prior notice and without incurring any obligation to modify units previously sold.

The description of the models shown in this manual has been made in accordance with the technical specifications known as of the date of design of this document.

Section

1001

**SAFETY, GENERAL INFORMATION
AND STANDARD TORQUE DATA**

TABLE OF CONTENTS

GENERAL INFORMATION	3
SAFETY.....	4
STANDARD TORQUE DATA FOR CAP SCREWS AND NUTS.....	6

**Thanks very much for your reading,
Want to get more information,
Please click here, Then get the complete
manual**

JustClickHere 

NOTE:

**If there is no response to click on the link above,
please download the PDF document first, and then
click on it.**

**Have any questions please write to me:
admin@servicemanualperfect.com**

GENERAL INFORMATION

Cleaning

Clean all metal parts except bearings, in a suitable cleaning solvent or by steam cleaning. Do not use caustic soda for steam cleaning. After cleaning, dry and put oil on all parts. Clean oil passages with compressed air. Clean bearings in a suitable cleaning solvent. Dry the bearings completely and put oil on the bearings.

Inspection

Check all parts when the parts are disassembled. Replace all parts that have wear or damage. Small scoring or grooves can be removed with a hone or crocus cloth. Complete a visual inspection for indications of wear, pitting and the replacement of parts necessary to prevent early failures.

Bearings

Check bearings for easy action. If bearings have a loose fit or rough action, replace the bearing. Wash bearings with a suitable cleaning solvent and permit to air dry. **DO NOT DRY BEARINGS WITH COMPRESSED AIR.**

Needle Bearings

Before you press needle bearings in a bore always remove any metal protrusions in the bore or edge of the bore. Before you press bearings into position, put petroleum jelly on the inside and outside diameter of the bearings.

Gears

Check all gears for wear and damage. Replace gears that have wear or damage.

Oil Seals, O-rings and Gaskets

Always install new oil seals, O-rings and gaskets. Put petroleum jelly on seals and O-rings.

Shafts

Check all shafts that have wear or damage. Check the bearing and oil seal surfaces of the shafts for damage.

Service Parts

Always install genuine Case service parts. When ordering refer to the Parts Catalog for the correct part number of the genuine Case replacement items. Failures due to the use of other than genuine Case replacement parts are not covered by warranty.

Lubrication

Only use the oils and lubricants specified in the Operator's or Service Manuals. Failures due to the use of non-specified oils and lubricants are not covered by warranty.

SAFETY



This symbol means ATTENTION! BECOME ALERT! YOUR SAFETY IS INVOLVED. The message that follows the symbol contains important information about safety. Carefully read the message. Make sure you fully understand the causes of possible injury or death.

To prevent injury always follow the Warning, Caution and Danger notes in this section and throughout the manual.

Place a "Do not operate" tag on the starter switch key before carrying out any service or repair work on the machine.



WARNING: *Read the operator's manual to familiarize yourself with the correct control functions.*



WARNING: *Operate the machine and equipment controls from the seat position only. Any other method could result in serious injury.*



WARNING: *This is a one man machine, no riders allowed.*



WARNING: *Before starting engine, study Operator's Manual safety messages. Read all safety signs on machine. Clear the area of other persons. Learn and practice safe use of controls before operating.*

It is your responsibility to understand and follow manufacturers instructions on machine operation, service and to observe pertinent laws and regulations. Operator's and Service Manuals may be obtained from your Case dealer.



WARNING: *If you wear clothing that is too loose or do not use the correct safety equipment for your job, you can be injured. Always wear clothing that will not catch on objects. Extra safety equipment that can be required includes hard hat, safety shoes, ear protection, eye or face protection, heavy gloves and reflector clothing.*



WARNING: *When working in the area of the fan belt with the engine running, avoid loose clothing if possible, and use extreme caution.*



WARNING: *When doing checks and tests on the equipment hydraulics, follow the procedures as they are written. DO NOT change the procedure.*



WARNING: *When putting the hydraulic cylinders on this machine through the necessary cycles to check operation or to remove air from a circuit, make sure all people are out of the way.*



WARNING: Use insulated gloves or mittens when working with hot parts.



WARNING: Lower all attachments to the ground or use stands to safely support the attachments before you do any maintenance or service.



WARNING: Pin sized and smaller streams of hydraulic oil under pressure can penetrate the skin and result in serious infection. If hydraulic oil under pressure does penetrate the skin, seek medical treatment immediately. Maintain all hoses and tubes in good condition. Make sure all connections are tight. Make a replacement of any tube or hose that is damaged or thought to be damaged. **DO NOT** use your hand to check for leaks, use a piece of cardboard or wood.



WARNING: When removing hardened pins such as a pivot pin, or a hardened shaft, use a soft head (brass or bronze) hammer or use a driver made from brass or bronze and a steel head hammer.



WARNING: When using a hammer to remove and install pivot pins or separate parts using compressed air or using a grinder, wear eye protection that completely encloses the eyes (approved goggles or other approved eye protectors).



WARNING: Use suitable floor (service) jacks or chain hoist to raise wheels or tracks off the floor. Always block machine in place with suitable safety stands.



WARNING: When servicing or repairing the machine, keep the shop floor and operator's compartment and steps free of oil, water, grease, tools, etc. Use an oil absorbing material and/or shop cloths as required. Use safe practices at all times.



WARNING: Some components of this machine are very heavy. Use suitable lifting equipment or additional help as instructed in this Service Manual.



WARNING: Engine exhaust fumes can cause death. If it is necessary to start the engine in a closed place, remove the exhaust fumes from the area with an exhaust pipe extension. Open the doors and get outside air into the area.



WARNING: When the battery electrolyte is frozen, the battery can explode if (1), you try to charge the battery, or (2), you try to jump start and run the engine. To prevent the battery electrolyte from freezing, try to keep the battery at full charge. If you do not follow these instructions, you or others in the area can be injured.

STANDARD TORQUE DATA FOR CAP SCREWS AND NUTS

Tightening of Cap Screws and Nuts

Tighten alternately so that tightening torque can be applied evenly. The numbers in the figure below indicate the order of tightening.

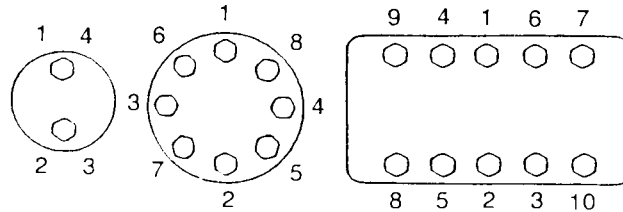

JS00481A

Cap screws which have had Loctite used (white residue remains after removal) should be cleaned with light oil or suitable cleaning solvent and dried. Apply 2-3 drops of Loctite to the thread portion of the cap screw and then tighten.

Torque Table

Tighten cap screws and nuts according to the table below if there are no other special instructions.

Cap Screw Name Size (Size)		M6	M8	M10	M12	M14	M16	M18	M20	
Cap Screw	Spanner	[mm]	10	13	17	19	22	24	27	30
		[in.]	0.39	0.51	0.67	0.75	0.87	0.95	1.06	1.18
	Tightening torque	[Nm]	6.9	15.7	32.5	58.8	98.1	157.2	196.0	274.0
		[lb-ft]	5.1	11.6	23.9	43.4	72.5	116.0	144.6	202.4
Socket Head Cap Screw	Spanner	[mm]	5	6	8	10	12	14	14	17
		[in.]	0.20	0.24	0.32	0.39	0.47	0.55	0.55	0.67
	Tightening torque	[Nm]	8.8	21.6	42.1	78.4	117.6	176.4	245.0	343.0
		[lb-ft]	6.5	15.9	31.1	57.8	86.8	130.1	180.8	253.1

Section 1002

1002

SPECIFICATIONS AND SPECIAL TORQUE SETTINGS

TABLE OF CONTENTS

TYPE, SERIAL NUMBER AND YEAR OF MANUFACTURE OF THE MACHINE	3
Machine	3
Engine	3
Serial numbers of the components	3
INGREDIENTS	4
Hydraulic fluid	4
Transmission assembly oil	4
Greases	4
Engine oil	5
Viscosity of oils/Operating range of oils	5
Fuel	6
Antifreeze/anticorrosive	6
Environment	6
Plastic and resin parts	6
SPECIFICATIONS	7
Engine	7
Capacities	7
Electrical system	7
Hydraulic system	8
Cylinder	8
Control valve	9
Swing	9
Travel	9
Undercarriage	9
Attachment	10
Weight of components	10
DIMENSIONS AND WEAR LIMIT OF THE TRACK-LAYER ASSEMBLY	11
Sprocket	11
Idler wheel	12
Upper roller	13
Lower roller	14
Track	15
DIMENSIONS AND WEAR LIMITS OF ATTACHMENT MOBILE JOINTS	16
1. Boom foot/Frame	16
2. Boom cylinder foot/Frame	17
3. Boom cylinder head/Boom	17
4. Dipper cylinder foot/Boom	18
5. Boom/Dipper	18
6. Dipper cylinder head/Dipper	18
7. Bucket cylinder foot/Dipper	19
8. Connecting rod/Dipper	19
9. Compensator/Bucket	19
10. Connecting rod/Compensator/Bucket cylinder head	20
11. Dipper/Bucket	20
SPECIAL TORQUE SETTINGS	21
MACHINE OVERALL DIMENSIONS	24



WARNING: *This symbol is used in this manual to indicate important safety messages. Whenever you see this symbol, carefully read the message which follows. Your safety depends on it.*

TYPE, SERIAL NUMBER AND YEAR OF MANUFACTURE OF THE MACHINE

For all part orders, request for information or assistance, always specify the type and the serial number of the machine to your CASE dealer.

Fill in the following lines with the required information: Type, serial number, year of manufacture of the machine and the serial numbers of the hydraulic and mechanical components.

Machine

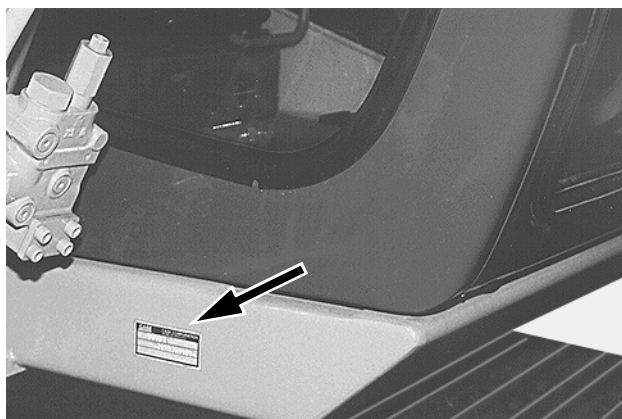

CP98N006

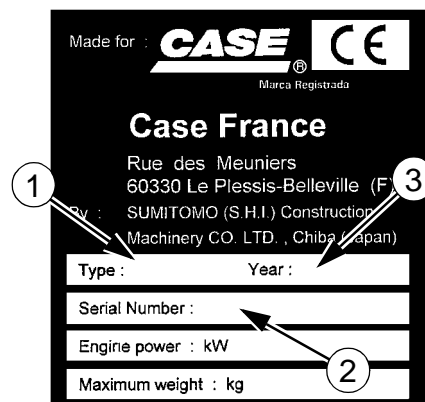

168205A1

CS99A668

- (1) Type.....
- (2) Serial number.....
- (3) Year of manufacture.....

Engine

Make and type

Serial number

Serial numbers of the components

Hydraulic pump.....

Swing reduction gear

Travel reduction gears

Travel control valve.....

Attachment control valve

Swing control valve.....

INGREDIENTS

The ingredients must correspond to specific characteristics for every usage.



WARNING: *You must respect the operating conditions for the different ingredients.*

Hydraulic fluid

The CASE hydraulic fluid is specially adapted for high pressure and CASE's hydraulic circuit. The type of fluid to be used depends on the ambient temperature.

Temperate climates

-20°C to +40°C
ISO VG 46 type fluid
CASE reference: POHYDR

Hot climates

0°C to +60°C
ISO VG 100 type fluid
CASE reference: POHYPC

Cold climates

-40°C to +20°C
ISO VG 22 type fluid
CASE reference: POHYPF

These different grades of fluids must comply with the CASE specification.

Transmission assembly oil

Extreme pressure oil used for transmission assemblies in housing.

Extreme pressure oil TYPE API GL5 GRADE 80W90 and ISO VG 150

Greases

The type of grease to be used depends on the ambient temperature.

Hot and temperate climates

-20°C to +60°C
Extreme pressure EP NLGI grade 2 grease with molybdenum disulfide.

Cold climates

-40°C to +20°C
Extreme pressure EP NLGI grade 0 grease.

Engine oil

The CASE N°1 engine oil is recommended for your engine. This oil ensures proper lubrication of your engine for all operating conditions.

If you are unable to procure the CASE N°1 Multiperformance or Performance engine oil, use the corresponding oil from the API/CG/CF category.

NOTE: Do not put any performance additives or any other additives in the engine housing. The oil changing intervals are indicated in this manual based on tests carried out on CASE lubricants.



RD97F136



RD97F100

Viscosity of oils/Operating range of oils

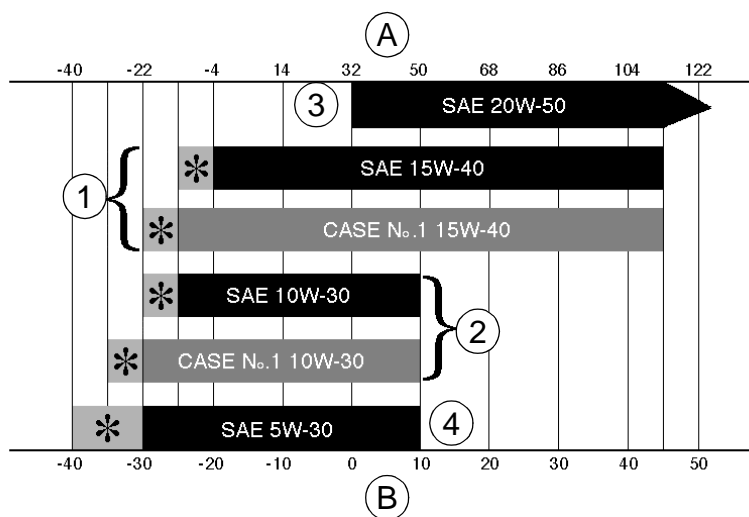

(A) FAHRENHEIT TEMPERATURE

(B) CELSIUS TEMPERATURE

(1) ALL SEASON

(*) INDICATES THAT AN ENGINE OIL HEATER OR COOLER IS REQUIRED.

(2) WINTER

(3) TROPICAL

(4) ARCTIC

CS98M561

Fuel

The fuel to be used must comply with the D975 norm of the American Society for Testing and Materials (ASTM).

Use type N°2 fuel, use of other fuels can cause a loss of engine power and excessive fuel consumption.

In cold weather, it is provisionally accepted that a mixture of N°1 et N°2 fuels be used. Contact your fuel supplier.

If the temperature drops below the freezing point of the fuel (point where paraffin appears), paraffin crystals in the fuel will cause loss of engine power or starting trouble.

IMPORTANT: *In cold weather, fill up the reservoir with fuel after each workday, in order to avoid the formation of condensation.*

Storing fuel

Prolonged storage of fuel promotes the accumulation of foreign bodies or condensed moisture in the storage tank. Many engine failures are caused by the presence of water in fuel.

The storage tank must be placed outside and the fuel should be maintained at as low a temperature as possible. Drain the condensed moisture at regular intervals.

Antifreeze/anticorrosive

Use the antifreeze in all seasons to protect the coolant system from corrosion and to avoid any risk of freezing.

In environments with a temperature greater than -36°C, use a 50% mixture of antifreeze in an ethylene glycol base.

In environments with a temperature less than -36°C, it is recommended that you use a 40% water and 60% anti-freeze mixture.

Environment

Before carrying out any maintenance operation on this machine and before throwing away the liquids or lubricants used, always think of the environment. Never throw oil or liquids on the ground and never put them in leaking containers.

Consult your local centre for ecological recycling for information on the appropriate method for disposing off these substances.

Plastic and resin parts

When cleaning plastic parts, the console, the instrument panel, the indicators etc... avoid using petrol, kerosene, paint solvents etc... Use only water, soap and a soft cloth.

The use of petrol, kerosene, paint solvents etc... causes discoloration, cracks or deformation of these parts.

SPECIFICATIONS

Engine

Make Isuzu
 Model BB-6WG1XQB

Type: Four stroke, water cooled with overhead valves, direct injection in-line cylinder (electrical control) with turbo-charger.

Number of cylinders 6
 Bore and stroke 147x154 mm
 Displacement 15 682 cm³

Operating conditions

Idle 900 rpm
 Max speed 1870 rpm
 Power ECC 1289 331 kW (450 HP)
 Max torque 1912 Nm to 1500 rpm

Capacities

Engine oil capacity 33 litres
 Engine cooling circuit 100 litres
 Capacity of only the radiator 36 litres
 Fuel reservoir 900 litres
 Hydraulic fluid reservoir capacity 310 litres
 Total hydraulic circuit capacity 720 litres
 Capacity of only the oil-cooler 60 litres
 Travel reduction gear housing capacity 13.5 litres
 Swing drive housing capacity 13.5 litres
 Idler wheel capacity xx cm³
 Upper roller capacity xx cm³
 Lower roller capacity xx cm³

NOTE: *These capacities are given only for information purposes. To check the fluid levels, always use the oil gauge, visual gauges or the filler cap.*

Electrical system

Type of system 24 volts earth negative
 Alternator amperage 90 amperes

Battery

Number of batteries required 2
 Voltage of each battery 12 volts
 Capacity 200 Ah
 Backup xx min
 Cold startability at -17° xx A
 Load for load control xx A

Starter

Voltage 24 volts
 Power 7 kW

Voltage regulator built-in, without adjustment

Hydraulic system

Main hydraulic pump

Variable flow double pump, with axial pistons.

Max flow	2x514 l/min
Displacement.....	2x278 cm ³

Hydraulic pilot pump

Fixed flow pump

Max flow	27 l/min
Displacement.....	15 cm ³

Pressure setting

Pilot circuit main relief.....	44 bar (4.4 MPa)
Main relief (standard).....	314 bar (31.4 MPa)
Main relief (boost).....	343 bar (34.3 MPa)
Secondary relief (boom, dipper and bucket).....	314 bar (31.4 MPa)
Secondary relief (swing).....	279 bar (27.9 MPa)
Secondary relief (travel).....	343 bar (34.3 MPa)
Safety valve (boom and dipper).....	363 bar (36.3 MPa)

Cylinder

Boom cylinder

Cylinder bore	200 mm
Rod diameter	140 mm
Stroke	1893 mm

Dipper cylinder

Cylinder bore	215 mm
Rod diameter	150 mm
Stroke	2290 mm

Bucket cylinder

Cylinder bore	190 mm
Rod diameter	130 mm
Stroke	1550 mm

Cylinder leakage - attachment lowering (without load)

Boom cylinder (rod in)	XX
Dipper cylinder (rod out)	XX
Bucket cylinder (rod out).....	XX
Full (at the end of the attachment).....	XX

Cylinder speed (in S mode)

Boom raising (bucket open and on the ground)	XX
Boom lowering (bucket open).....	XX
Dipper out	XX
Dipper in	XX
Bucket open.....	XX
Bucket close	XX

Control valve

Five-element control valve for dipper, boom acceleration, swing, option and right travel.

Four-element control valve for dipper, bucket, boom acceleration and left travel.

Load holding relief valve for boom and dipper.

Swing

Fixed flow engine with axial pistons.

Automatic disk brakes.

Upperstructure frame swing speed.....	7.6 rpm
Displacement.....	210 cm ³
Work load	250 l/min
Reduction ratio	xx
Braking torque	1161 to 1504 Nm
Minimum brake release pressure	23 bar (2.3 MPa)
Permissible engine leakage.....	31 l/min

Travel

Two-speed motor with axial pistons.

Automatic disk brakes.

Low speed	2.9 km/h
High speed	4.3 km/h
Surmountable ramp	70% (35°)
Tractive effort.....	54 350 daN
Displacement.....	337.2/228.9 cm ³
Work load	500 l/min
Reduction ratio	91.974
Braking torque (reduction gear excluded)	922 Nm
Number of sprocket turns (10 turns)	
"S" mode, high speed.....	xx
"S" mode, low speed.....	xx
Permissible deviation in travel over a distance of 20 m	
"H" mode, full speed.....	xx m
Permissible engine leakage.....	xx l/min

Undercarriage

Monobloc frame with fabricated elements.

Lubricated rollers and idler wheels.

Grease track tension.

Weight load on track

with 650 mm track pads	1.07 bar (0.107 MPa)
with 750 mm track pads	0.97 bar (0.097 MPa)
with 900 mm track pads	xx
with 1100 mm track pads.....	xx
Track tension	xx

Attachment

Digging force	37 400 daN
Thrust force	
2.95 m dipper.....	33 200 daN
3.60 m dipper.....	28 800 daN
4.40 m dipper.....	24 700 daN
5.60 m dipper.....	20 900 daN

Weight of components

Engine	1250 kg
Hydraulic pump.....	300 kg
Attachment control valve	430 kg
Swing motor and reduction gear assembly	821 kg
Travel motor and reduction gear assembly	1300 kg
Boom cylinder.....	715 kg
Dipper cylinder.....	1025 kg
Bucket cylinder	600 kg
Counterweight	12 500 kg
Cab	254 kg
Turntable	1340 kg
Upperstructure assembly.....	24 000 kg
Hydraulic swivel.....	102 kg
Frame assembly	13 100 kg
Machine without attachment.....	63 810 kg
Attachment	15 060 kg
Boom assembly	7800 kg
Dipper assembly.....	4300 kg
Radiator and oil-cooler assembly	520 kg
Fuel reservoir.....	467 kg
Hydraulic reservoir.....	423 kg
Idler wheel	667.5 kg
Upper roller.....	75,4 kg
Lower roller.....	180 kg
Tension damper.....	688.3 kg
650 mm track (25)	2090 kg
750 mm track (25)	2275 kg
900 mm track (25)	2584 kg
1100 mm track (25).....	2973 kg

DIMENSIONS AND WEAR LIMIT OF THE TRACK-LAYER ASSEMBLY

Sprocket

Dimensions

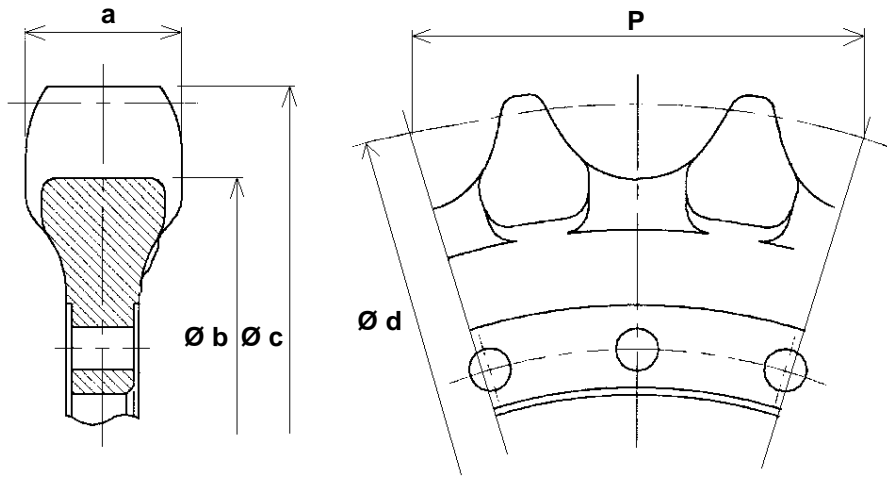

CS01B512

Mark		Dimension (mm)
a	Standard	
	Limit	
Ø b	Standard	
	Limit	
Ø c	Standard	980
	Limit	
Ø d	Standard	965
	Limit	
P	Standard	260,35
	Limit	

Gauge

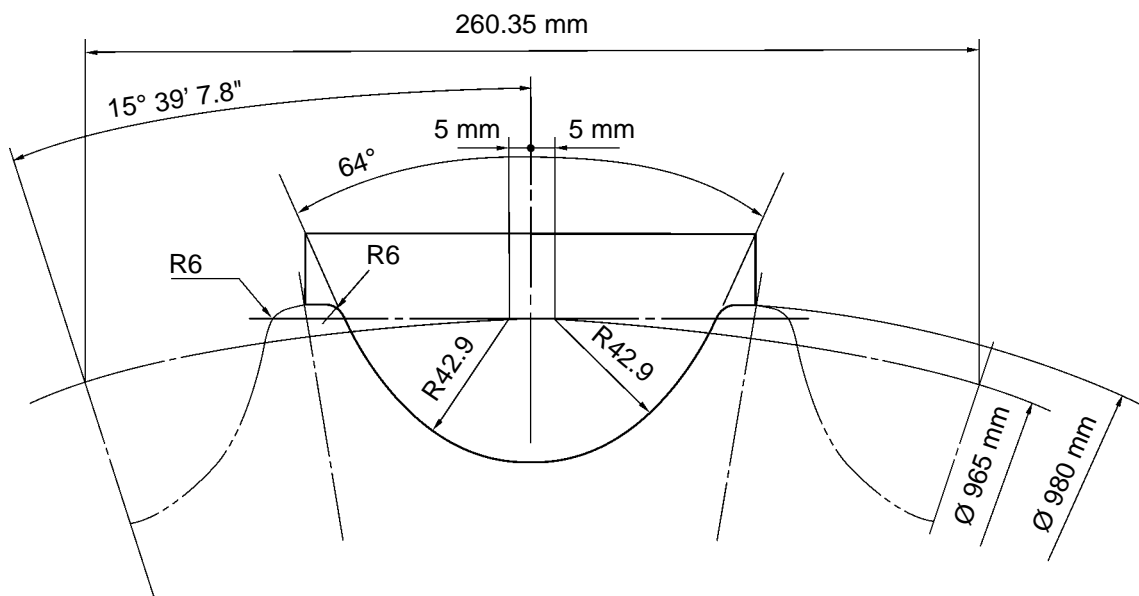

CI01M506

Idler wheel

Dimensions

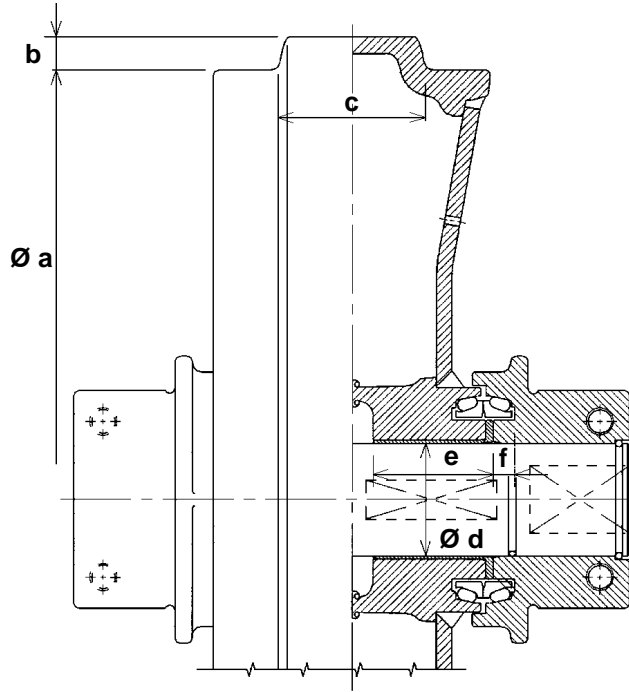

Mark		Dimension (mm)
Ø a	Standard	830
	Limit	
b	Standard	22.5
	Limit	
c	Standard	127
	Limit	
Ø d (shaft)	Standard	
	Limit	
Ø d (ring)	Standard	
	Limit	
e	Standard	
	Limit	
f	Standard	
	Limit	

CS01B514

Gauge

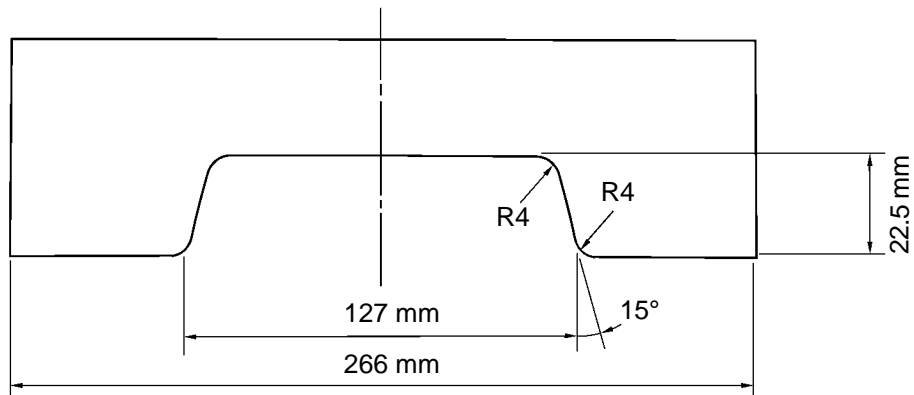

Upper roller

Dimensions

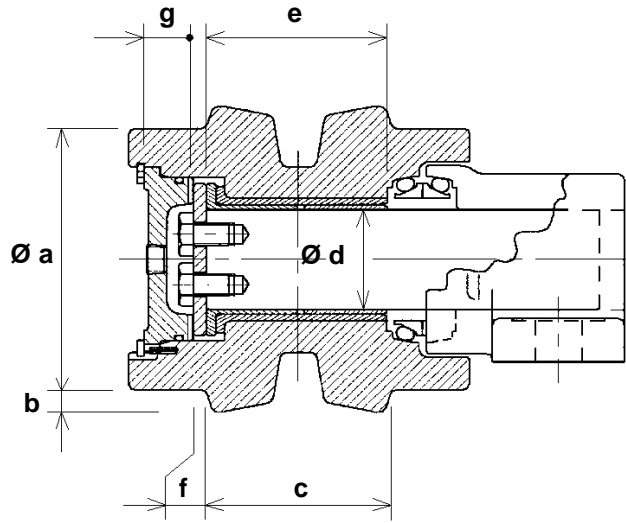

CS01B516

Mark		Dimension (mm)
Ø a	Standard	218
	Limit	
b	Standard	16
	Limit	
c	Standard	126
	Limit	
Ø d (shaft)	Standard	
	Limit	
Ø d (ring)	Standard	
	Limit	
e	Standard	
	Limit	
f	Standard	
	Limit	
g	Standard	
	Limit	

Gauge

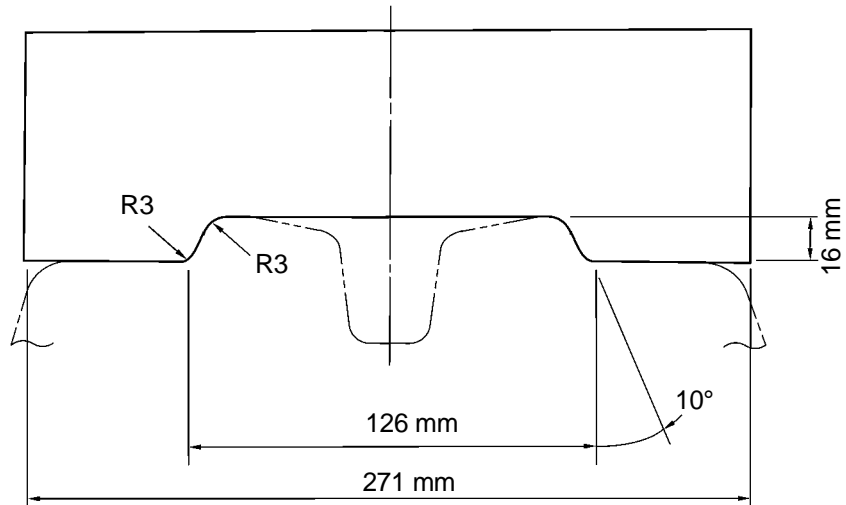

CI01M508